

## 2.2 发动机附件/Engine Accessories

序号/ No.	名 称 / Designation		页 码 / Page No.
2.2.01	HOWO矿用自卸车进气系统(D12) /Air Intake System	.....	1
2.2.02	冷却系统(70T矿车装D12发动机/868散热器/768风扇/机械变速箱/不装缓速器)/Cooling System	.....	3
2.2.03	暖风系统(矿车/D12/底盘部分)/Warm Wind System	.....	7
2.2.04	HOWO排气系统(D12国二/70T矿用自卸车) /Exhaust System	.....	8
2.2.05	500L/D型油箱燃油系(矿用自卸车/10L国II、国III)/Fuel Tank&Pipe	.....	10
2.2.06	HOWO油门操纵系统(70吨矿车/D12)/Accelerator Control System	.....	12
2.2.07	发动机悬置(D121150宽车架10+10矿用自卸车)/Engine Mounting	.....	16

## 2.2.01 HOWO矿用自卸车进气系统(D12) /Air Intake System

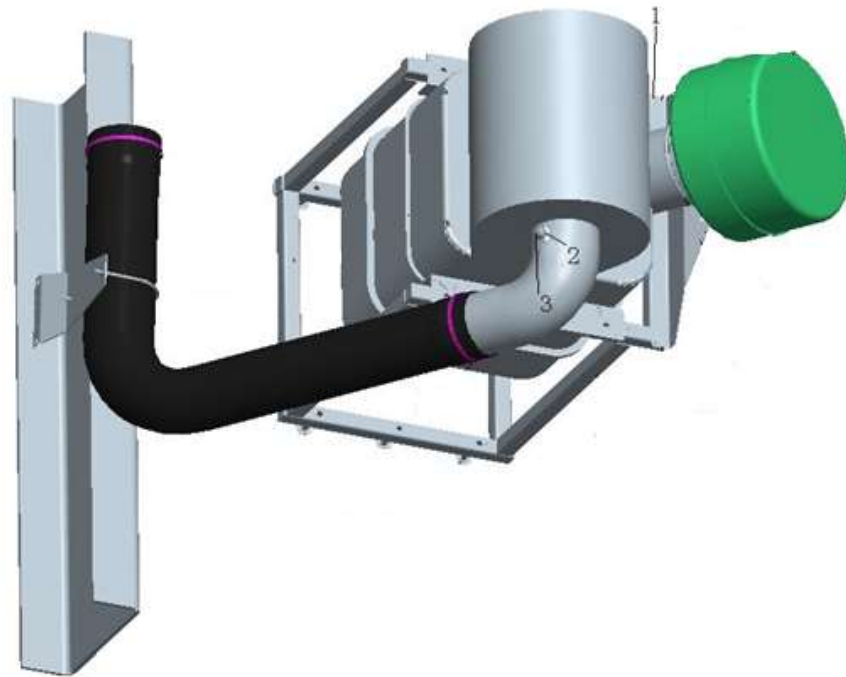

## 2.2.01 HOWO矿用自卸车进气系统(D12) /Air Intake System

序号 No.	零部件图号 Part No.	名称	Part Name	数量 Qty	备注 Remark
1	TF9770190021-00	70矿油浴式空滤器分装总	Air cleaner	1	
2	WG1200190040	干式空滤器堵塞指示器开	Switch	1	
3	WG9100770028	保护罩	Cover	1	
4	TG12573651001	横梁用角支架	Bracket	6	
5	TG12573651002	横梁用角支架	Bracket	1	
6	TG12573651003	U形支架	U Bracket	4	
7	WG9719190046	橡胶套管	Rubber casing	1	
8	WG9770190023	支架	Bracket	1	
9	WG9770190024	U型卡箍	U clamp	1	
10	WG9770190032	进气钢管	Pipe	1	
11	WG9770190033	进气胶管	Hose	1	
12	AZ9003980025	软管卡箍, 145/185 N050	Hose clamp	3	
13	Q150B1065	六角头螺栓	Hexagon head bolts	2	
14	Q18614100	六角法兰面螺栓—加大系	Hexagon bolts with flange	8	
15	Q33214	2型全金属六角锁紧螺母	Nut	8	
16	Q340B08	1型六角螺母	Hexagon nuts ,style 1	6	
17	Q340B10	六角螺母	Nut	2	
18	Q40108	平垫圈	Washer	6	
19	Q40210	大垫圈	Washer	4	
20	Q40214	大垫圈	Washer	8	

## 2.2.01 HOWO矿用自卸车进气系统(D12) /Air Intake System

1 /2/3/4 /5



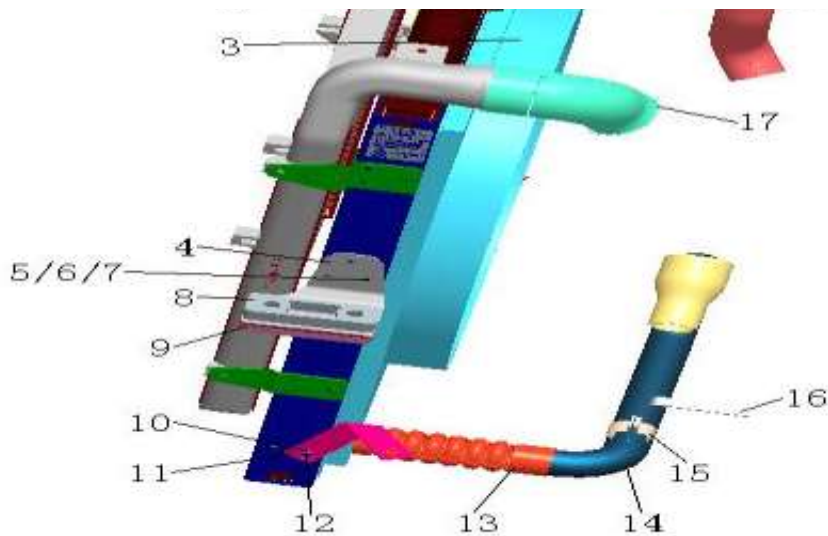

2.2.02 冷却系统(70T矿车装D12发动机/868散热器/768风扇/机械变速箱/不装缓速器)/Cooling System

序号 No.	零部件图号 Part No.	名称	Part Name	数量 Qty	备注 Remark
1	WG9770530080	中冷器总成	Intercooler assembly	1	
2	WG9770530070	散热器总成	Radiator	1	
3	WG9770530006	风扇护风罩	Fan shroud	1	
4	WG9725538201	垫板	Plate	2	
5	ZQ150B10110	六角头螺栓M10	Hexagon head bolts	4	
6	Q40110	平垫圈	Washer	4	
7	ZQ340B10	1型六角螺母M10*1.5	Hexagon nuts ,style 1	4	
8	WG9725538202	散热器上减振垫总成	Cushion	2	
9	WG9725538203	散热器下减振垫总成	Cushion	2	
10	WG9412531317	橡胶垫块	Cushion	2	
11	WG9770530043	散热器左拉板	Radiator bracket	1	
12	WG9725538220	套管	Sleeve	4	
13	WG9770530098	出水胶管	Pipe	1	
14	WG9770530091	散热器出水钢管总成	Pipe	1	
15	WG9925530055	分体式管夹总成	Pipe clamp assembly	1	
16	WG9770530093	出水钢管支架	Bracket	1	
17	WG9770530113	中冷器出气胶管	Pipe	1	
18	WG9770530008	散热器进水胶管	Pipe	1	
19	WG9770530111	中冷器进气胶管	Pipe	1	
20	WG9925530009	下水室胶管	Hose	1	

2.2.02 冷却系统(70T矿车装D12发动机/868散热器/768风扇/机械变速箱/不装缓速器)/Cooling System

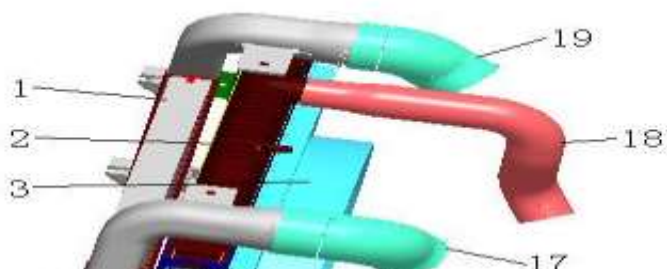

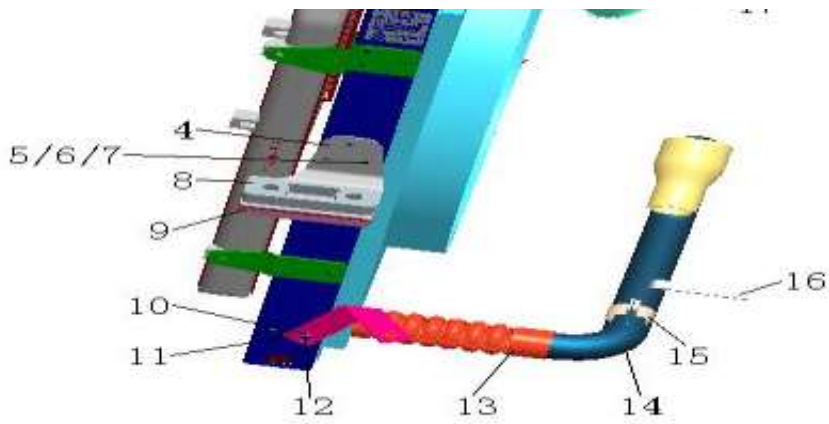

2.2.02 冷却系统(70T矿车装D12发动机/868散热器/768风扇/机械变速箱/不装缓速器)/Cooling System

序号 No.	零部件图号 Part No.	名称	Part Name	数量 Qty	备注 Remark
21	WG9770530044	散热器右拉板	Radiator bracket	1	
22	ZQ340B08	1型六角螺母M8	Hexagon nuts ,style 1	2	
23	Q40308	弹簧垫圈	Spring washer	2	
24	Q341B08	1型六角螺母-细牙	Nut	2	
25	ZQ150B0825	六角头螺栓M8	Hexagon head bolts	1	
26	ZQ340B08	1型六角螺母M8	Hexagon nuts ,style 1	1	
27	AZ9003980010	软管卡箍-60/79 N05074	Hose clamp	2	
28	190003990037	管夹	Clip	2	
29	AZ9003980010	软管卡箍-60/79 N05074	Hose clamp	2	
30	190003989310	软管卡箍	Hose clamp	2	
31	190003989314	软管卡箍	Hose clamp	1	
32	WG9925530022	卡箍	Clamp	3	
33	ZQ150B0816	六角头螺栓M8	Hexagon head bolts	8	
34	Q40108	平垫圈	Washer	8	
35	Q40308	弹簧垫圈	Spring washer	8	
36	WG9112530333	膨胀水箱总成	Expansion tank	1	
37	WG9719530037	膨胀箱胶管8*4500	Hose	1	
38	WG9719530034	膨胀水箱变径胶管3400	Hose	1	
39	Q68818	一端固定式双管夹片	Double tube clip	1	
40	ZQ150B0812	六角头螺栓M8	Hexagon head bolts	1	

2.2.02 冷却系统(70T矿车装D12发动机/868散热器/768风扇/机械变速箱/不装缓速器)/Cooling System

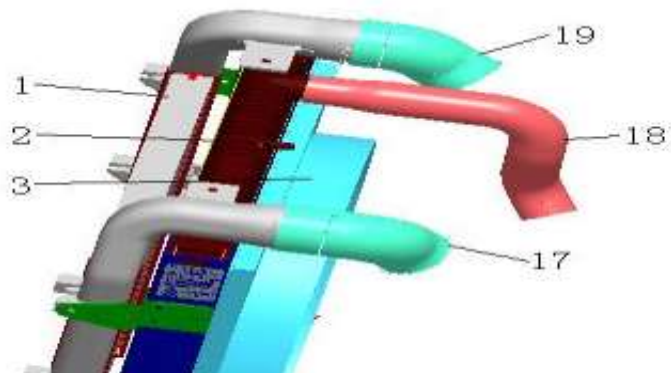

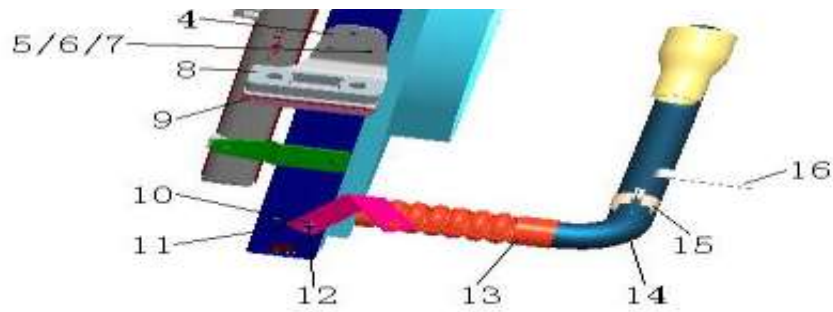

2.2.02 冷却系统(70T矿车装D12发动机/868散热器/768风扇/机械变速箱/不装缓速器)/Cooling System

序号 No.	零部件图号 Part No.	名称	Part Name	数量 Qty	备注 Remark
41	Q40308	弹簧垫圈	Spring washer	1	
42	Q40108	平垫圈	Washer	1	
43	WG9719530047	膨胀水箱L型胶管20*370	Hose	1	
44	WG9000530037	橡胶软管	Hose	1	
45	190003989340	软管卡箍	Hose clamp	10	
46	190003989300	软管卡箍	Hose clamp	6	
47	Q150B0820	六角头螺栓	Bolt	3	
48	Q40308	弹簧垫圈	Spring washer	3	
49	AZ9770530034	垫圈(外径38内径9)	Gasket	1	
50	AZ9770530026	膨胀水箱支架	Bracket of expansion tank	1	
51	WG9770530033	橡胶减震块	Rubber buffer	1	
52	Q40308	弹簧垫圈	Spring washer	3	
53	Q40108	平垫圈	Washer	3	
54	Q33008	全金属六角法兰面锁紧螺	Nut	1	
55	Q150B0830	六角头螺栓	Bolt	3	
56	WG9925360818	角形支架(三孔)	Bracket	3	
57	Q68618	单管夹片	Clip	4	
58	Q40206	大垫圈	Washer	6	
59	Q40306	弹簧垫圈	Spring washer	6	
60	Q40106	平垫圈	Washer	3	

2.2.02 冷却系统(70T矿车装D12发动机/868散热器/768风扇/机械变速箱/不装缓速器)/Cooling System

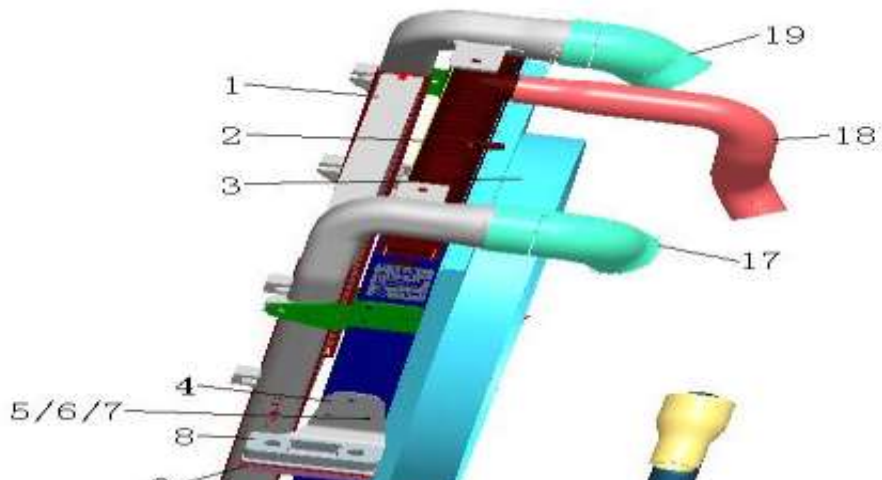

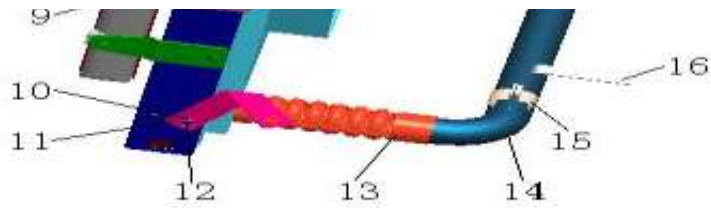

2.2.02 冷却系统(70T矿车装D12发动机/868散热器/768风扇/机械变速箱/不装缓速器)/Cooling System

序号 No.	零部件图号 Part No.	名称	Part Name	数量 Qty	备注 Remark
61	WG9725530151	橡胶垫块	Cushion	1	
62	ZQ340B06	1型六角螺母M6	Nut	3	
63	AZ9725530152	套管	Sleeve	1	
64	Q40210	大垫圈	Washer	1	
65	Q40310	弹簧垫圈	Spring washer	1	
66	ZQ150B1030	六角头螺栓M10	Hexagon head bolts	1	
67	WG9770530099	防虫网	Net	1	
68	Q40108	平垫圈	Washer	2	
69	Q40308	弹簧垫圈	Spring washer	2	
70	ZQ150B0825	六角头螺栓M8	Hexagon head bolts	2	
71	Q40008	小垫圈	Washer	2	
72	ZQ150B0635	六角头螺栓M6	Hexagon head bolts	3	
73	199012360441	角形支架	Bracket	1	
74	Q40308	弹簧垫圈	Spring washer	1	
75	ZQ150B0825	六角头螺栓M8	Hexagon head bolts	1	
76	Q40108	平垫圈	Washer	1	
77	Q40306	弹簧垫圈	Spring washer	3	
78	ZQ340B06	1型六角螺母M6	Nut	3	

2.2.03 暖风系统(矿车/D12/底盘部分)/Warm Wind System

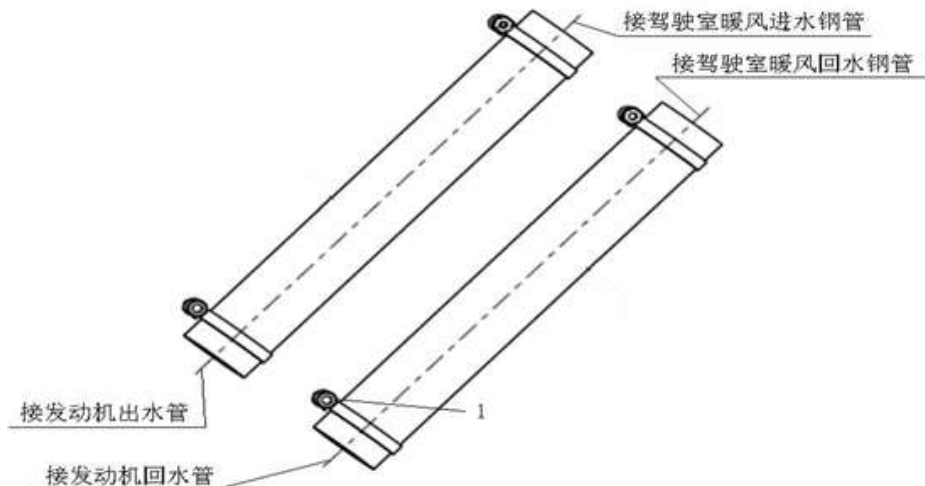



2.2.04 HOWO排气系统(D12国二/70T矿用自卸车) /Exhaust System

序号	零部件图号	名称	Part Name	数量	备注
No.	Part No.			Qty	Remark
1	WG9770540021	消声器总成	Muffler assembly	1	
2	WG9725540025	装饰板	Panel	1	
3	Q150B0620	六角头螺栓	Bolt	4	
4	Q40306	弹簧垫圈	Spring washer	4	
5	Q40206	大垫圈	Washer	4	
6	WG9719540008	拉紧杆	Rod	2	
7	AZ9719540017	隔热板	Heat shield	1	
8	Q40106	平垫圈	Washer	9	
9	Q150B0610	六角头螺栓	Bolt	9	
10	Q40108	平垫圈	Washer	4	
11	Q40308	弹簧垫圈	Spring washer	4	
12	Q340B08	1型六角螺母	Nut	4	
13	ZQ1811255TF6	六角法兰面带齿螺栓M12	Hexagon flange bolts with t	1	
14	ZQ1811245TF6	六角法兰面带齿螺栓M12	Hexagon flange bolts with t	2	
15	ZQ1811250TF6	六角法兰面带齿螺栓M12	Hexagon flange bolts with t	1	
16	ZQ32512T13F6	六角法兰面带齿螺母M12	Hexagon flange nuts with te	4	
17	AZ9770540002	消声器前支架	Bracket	1	
18	AZ9719540007	限位板	Plate	2	
19	AZ9770540003	消声器后支架	Bracket	1	
20	WG9770540025	U型螺栓	U-bolt	1	

2.2.04 HOWO排气系统(D12国二/70T矿用自卸车) /Exhaust System

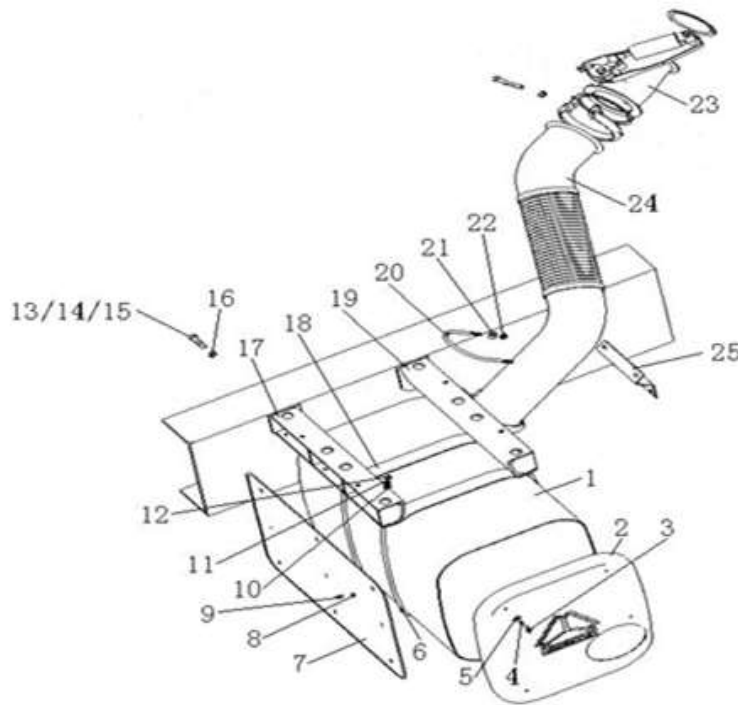

2.2.04 HOWO排气系统(D12国二/70T矿用自卸车) /Exhaust System

序号	零部件图号	名称	Part Name	数量	备注
----	-------	----	-----------	----	----



3	AZ9112550230	内六角螺栓	Bolt	2	
4	AZ9112550228	拉紧销	Strain pin	2	
5	190003171697	塑料紧箍带	Cable binder	6	
6	AZ9725550121	聚酰胺管 无色透明 16	Plastic tube	420cm	
7	AZ9725550121	聚酰胺管 无色透明 16	Plastic tube	50cm	
8	WG9725550025	管接头(16X2-M16)	Nozzle	2	
9	AZ9003090016	复合密封垫圈16 QZZ210	Gasket	4	
10	190003962627	空心螺栓	Hollow bolt	2	
12	AZ9770550001	粗滤器支架	Primary filter bracket	1	
14	AZ9725550121	聚酰胺管 无色透明 16	Plastic tube	450cm	
15	WG9725550026	管接头(16X2-M14)	Nozzle	2	
16	AZ9003179032	穿线护套	Shield sleeve	150mm	
17	WG9925550002	油位传感器(接16*2管)	Fuel level sensor	1	
18	199100550107	燃油箱盖	Fuel cover	1	
22	WG9770550128	板	Plate	2	
23	AZ9725550009	D型油箱支架总成	D-type ltank bracket assem	2	
24	WG9725550260	D型油箱拉带总成	D-type tank strap assembly	2	
24.1	WG9725550009	D型燃油箱紧固带(400L)	Strap	2	

2.2.05 500L/D型油箱燃油系(矿用自卸车/10L国II、国III)/Fuel Tank&Pipe

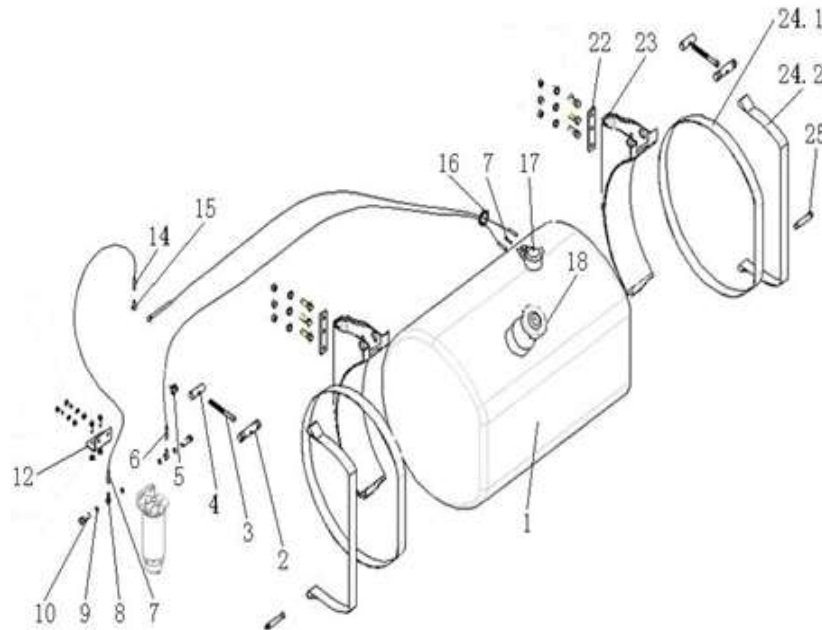

2.2.05 500L/D型油箱燃油系(矿用自卸车/10L国II、国III)/Fuel Tank&Pipe

序号	零部件图号	名称	Part Name	数量	备注
No.	Part No.			Qty	Remark
24.2	WG9725550010	D型燃油箱垫带(400L)	Strap	2	
25	AZ9112550229	拉紧销	Strain pin	2	
26	ZQ1811660TF6	六角法兰面带齿螺栓M16	Hexagon flange bolts with t	6	
27	ZQ32516T13F6	六角法兰面带齿螺母M16	Hexagon flange nuts with te	6	
28	AZ9112550121	聚酰胺管	Plastic tube	50cm	



9	Q40308	弹簧垫圈	Spring washer	2	
10	Q40108	平垫圈	Washer	2	
11	Q150B0815	六角头螺栓	Bolt	2	
12	WG9925570212	油门拉索总成	Accelerator cable assembly	1	
13	Q5100614	销轴	Pin	1	
14	Q5002014	开口销	Pin	1	
15	Q40106	平垫圈	Washer	1	
16	1288 570057	拉力弹簧	Spring washer	1	
17	AZ9719570085	挡板总成	Plate	1	
18	Q150B0640	六角头螺栓	Bolt	1	
19	Q340B06	I型六角螺母	Nut	1	
20	WG9719570081	控制轴总成	Control shaft	1	

### 2.2.06 HOWO油门操纵系统(70吨矿车/D12) /Accelerator Control System

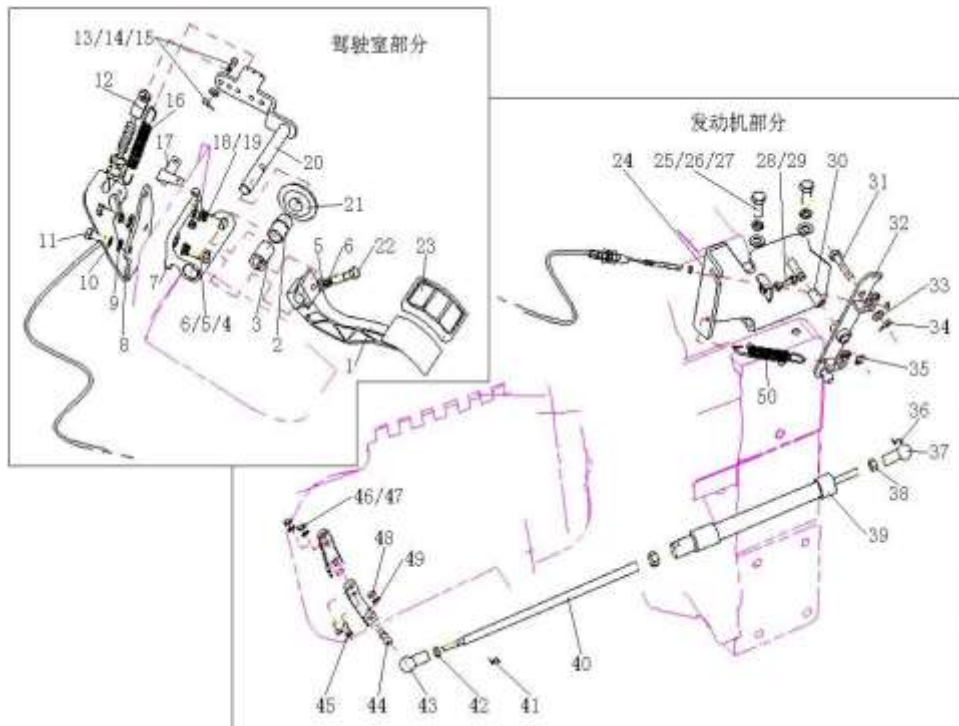

### 2.2.06 HOWO油门操纵系统(70吨矿车/D12) /Accelerator Control System

序号	零部件图号	名称	Part Name	数量	备注
No.	Part No.			Qty	Remark
21	WG9719570009	橡胶衬圈	Bushing	1	
22	Q150B0835	六角头螺栓	Bolt	1	
23	WG9719570001	油门踏板护套	Pedal cover	1	
24	WG9770570010	支架总成	Bracket	1	
25	Q150B1218	六角头螺栓	Bolt	2	
26	Q40112	平垫圈	Washer	2	
27	Q40312	弹簧垫圈	Spring washer	2	
28	Q150B0650Q	六角头螺栓	Bolt	1	
29	Q340B06	I型六角螺母	Nut	1	
30	WG99014180012	衬套	Bushing	1	
31	WG9012570084	销轴	Pin	1	

32	WG9770570023	杠杆总成	Lever	1	
33	Q40110	平垫圈	Washer	1	
34	Q5003216	开口销	Pin	1	
35	Q43680	开口挡圈	Circlip	1	
36	190003936514	卡箍	Clamp	1	
37	190003963623	带锁环的球形活节	Ball joint	1	
38	Q340B08	1型六角螺母	Nut	1	
39	WG9100570014	停油缸	Exhaust Brake Cylinder Fo	1	
40	WG9012570062	螺杆	Bolt	1	

## 2. 2. 06 HOWO油门操纵系统(70吨矿车/D12) /Accelerator Control System

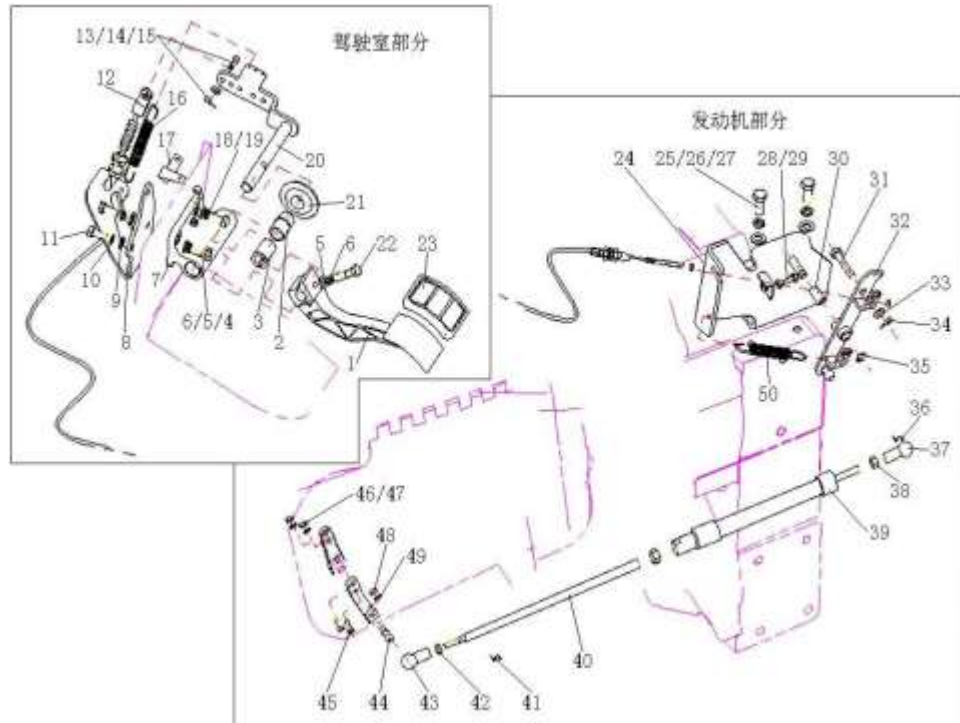

## 2. 2. 06 HOWO油门操纵系统(70吨矿车/D12) /Accelerator Control System

序号	零部件图号	名称	Part Name	数量	备注
No.	Part No.			Qty	Remark
41	190003936513	卡箍	Clamp	1	
42	Q340B06	I型六角螺母	Nut	2	
43	WG92 570025	球面活节总成	Ball joint assembly	1	
44	WG9003963313	球头销 (A10 DIN71803)	Ball pin	1	
45	Q150B0620	六角头螺栓	Bolt	2	
46	Q40306	弹簧垫圈	Spring washer	2	
47	Q33206	2型全金属六角锁紧螺母	Nut	2	
48	Q340B08	1型六角螺母	Nut	1	
49	Q40506	重型弹簧垫圈	Washer	1	
50	199100570065	拉力弹簧	Spring washer	1	
51	Q40108	平垫圈	Washer	2	
52	AZ9118570012	供油调节系统	Fuel adjust system	1	
53	AZ9725570131	连接弯板	Connection plate	1	
54	Q350B06T15	六角薄螺母	Nut	2	



2.2.07 发动机悬置 (D121150宽车架10+10矿用自卸车)/Engine Mounting

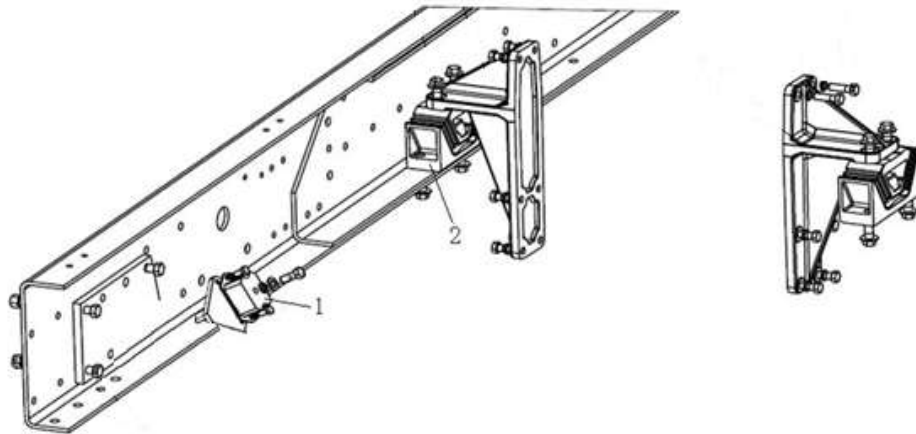

2.2.07 发动机悬置 (D121150宽车架10+10矿用自卸车)/Engine Mounting

序号 No.	零部件图号 Part No.	名称	Part Name	数量 Qty	备注 Remark
1	WG9770591001	发动机前支承	Front supporting of engine	2	
2	WG9770591021	楔形支承总成	Bracket assembly	2	
3	WG9770590022	前悬置右支架	Right before the suspension	1	
4	WG9770590021	前悬置左支架	Suspension before the left b	1	
5	WG9770590015	左支承托架	Left supporting bracket	1	
6	WG9770590016	右支承托架	Right supporting bracket	1	
7	ZQ1811645TF6	六角法兰面带齿螺栓M16	Hexagon flange bolts with t	4	
8	ZQ32316T13F6	六角法兰面螺母M16*1.5	Hexagon nuts with flange	4	
9	ZQ1811425TF6	六角法兰面带齿螺栓M14	Hexagon flange bolts with t	2	
10	ZQ1801030	六角法兰面带齿螺栓M10	Hexagon flange bolts with t	4	
11	ZQ32010	六角法兰面螺母M10	Hexagon nuts with flange	4	
12	WG9000310016	嵌入式锁紧垫圈 (M16)	Washer	4	
13	ZQ1851645TF6	六角法兰面螺栓M16*1.5	Hexagon bolts with flange	4	
14	ZQ1811645TF6	六角法兰面带齿螺栓M16	Hexagon flange bolts with t	4	
15	ZQ1811445TF6	六角法兰面带齿螺栓M14	Hexagon flange bolts with t	11	
16	ZQ1811450TF6	六角法兰面带齿螺栓M14	Hexagon flange bolts with t	1	